

LD024D Series

High Power Constant Current LED Driver

Total Power	24 Watts max.
Input Voltages	110VAC or 220VAC
Number of Outputs	One

SPECIAL FEATURES

- Compact size maximizes design flexibility.
- 85 (H) x 54 (W) x 32.5 (H) mm
- Fully potted, suitable for dry and damp location applications
- Phase dimmable, compatible with Standard Triac and Electronics Low Voltage Dimmers
- UL1310 Class 2 (110V) and CE compliant (220V) - Pending
- Wide selection of pre-adjusted C/C outputs

ENVIRONMENTAL

Operating temperature:	-20 to +60 °C
Storage temperature:	-40 to +85 °C
Humidity (Non-Condensing):	5% to 95%
Cooling:	Convection
Vibration Frequency:	5 to 50 Hz
MTBF:	>100,000 Hours at full load and 25°C ambient conditions (MIL-217F)

SPECIFICATIONS :

Input Range : 110VAC or 220VAC / 0.3~0.15A /47~63Hz	Power Factor: > 0.92 at full load, 115VAC
DC Output Range : Refer to Model selection table	Operation Temp. : -20°C ~ +50°C , Tc : 75 °C
Efficiency : 84% Typical	Storage Temp. : -40°C ~ +85°C
Output Current Regulation : ±5%	MTBF(@25°C) : >100,000 Hours, MIL-217F
Protection : OCP, SCP, OVP – Auto Recovery	Regulation Compliance: UL1310, EN61347, EN55015, EN61547
Dimming : Phase dimmer, leading or trailing edge	Dimension: 85 (H) x 54 (W) x 32.5 (H) mm

MODEL SELECTION : (110VAC only)

Model Number	DC Output (Vf)	Max. Current Output (mA)	Max. Output (Watts)
LD024D-C312020-15	10 – 20 VDC	1200	24
LD024D-C310024-15	12 – 28 VDC	1000	24
LD024D-C37036-15	18 – 40 VDC	700	24
LD024D-C35048-15	30 – 52 VDC	500	24

MECHANICAL

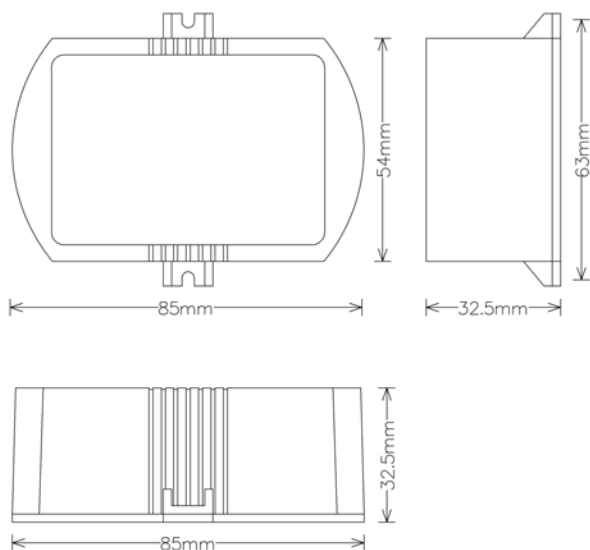

Preliminary Product Specifications

ANZ#: Z165, March 24, 2010



Picture shown above is not to scale

MODEL SELECTION : LDeed-Caxxyy-dd

LD = LED Driver
 eee = Output Wattage upto 24 Watts
 D = Phase dimmable
 C = Constant Current Output
 a = AC Input Voltage, 3 : 110VAC or 4 : 220VAC
 xxx = Output Current x 10
 yy = Output Voltage (VDC)