

CC3512 Application note

When using Magtech CC3512H with 0-10V controller:

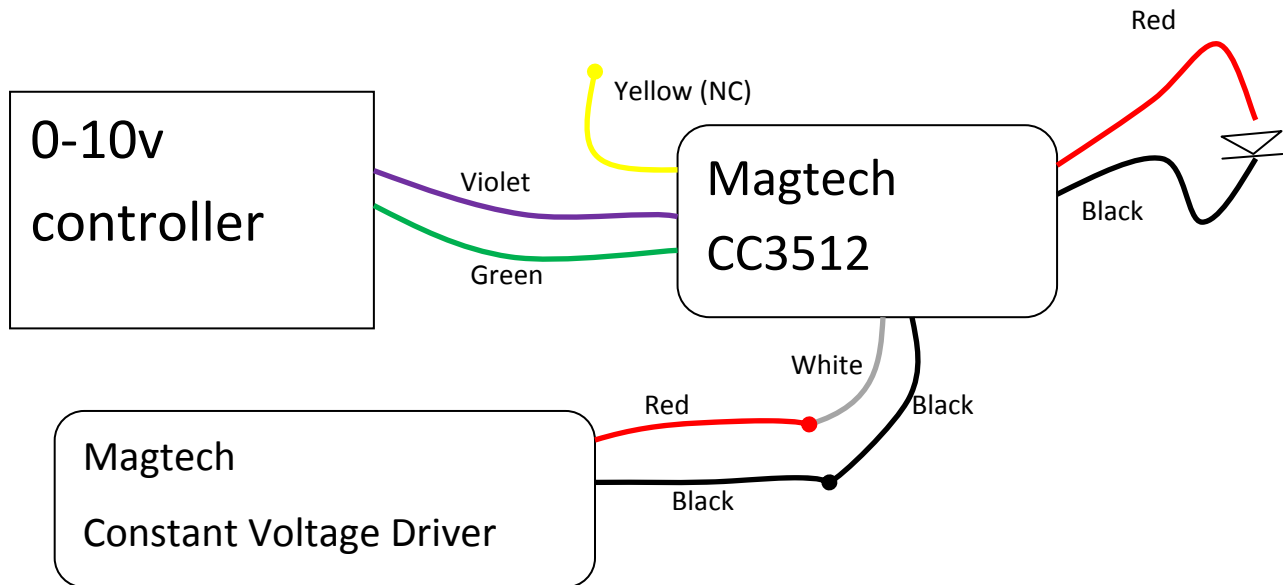

When using Magtech CC3512H with potentiometer:

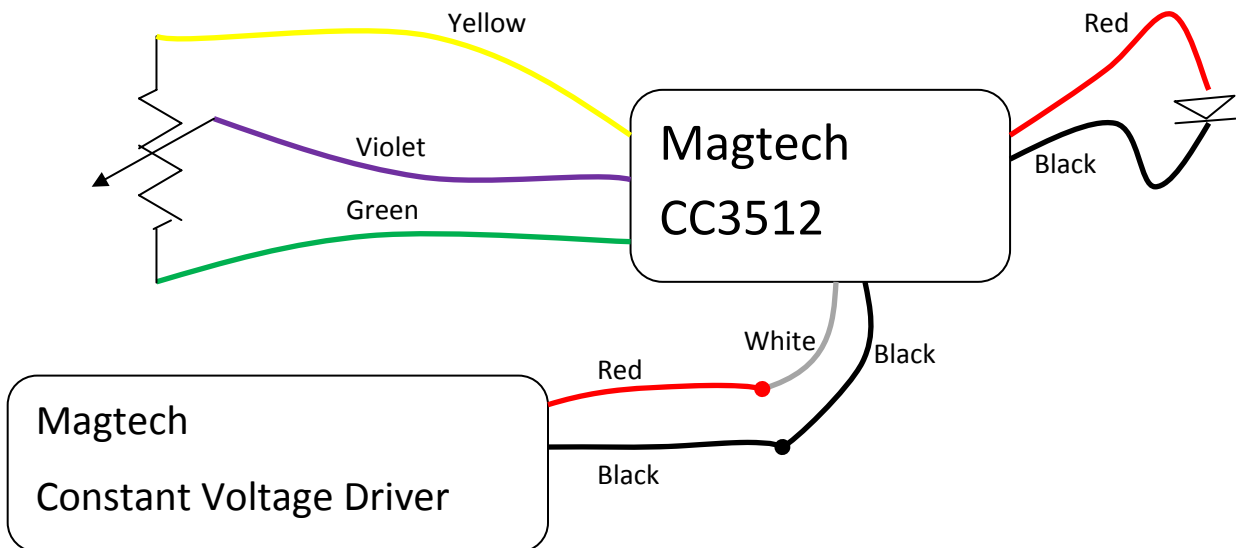

When using Magtech CC3512H with standard 0-10V florescent dimmer:

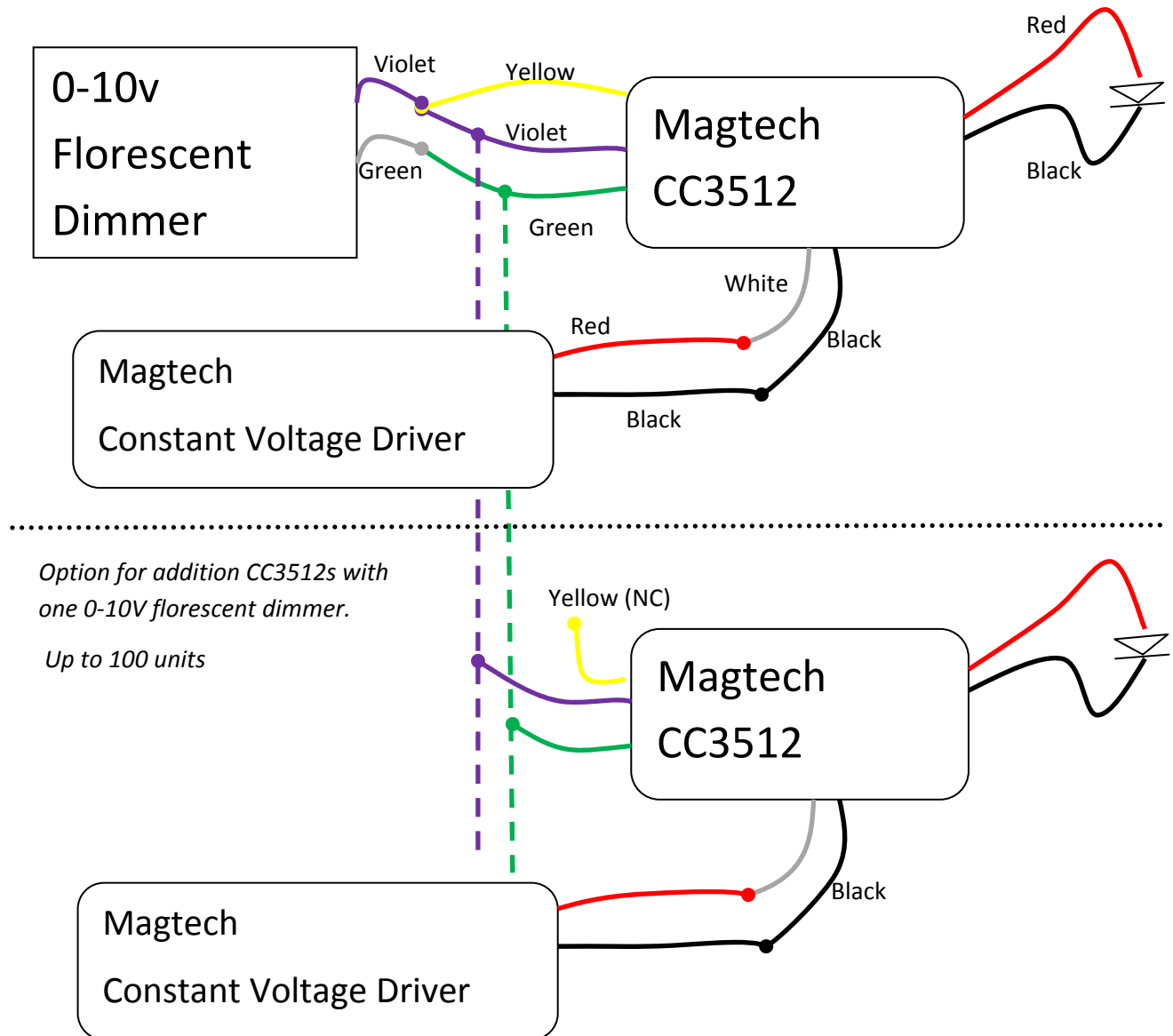

Disclaimer:

All of the above diagrams are for reference use only. Please make sure to comply with NEC code during installations. If you have any other questions, please feel free to call our customer service for more information.